

GALLETTO CON BOCCOLA
OTTONE CIECA
WING NUT, WITH THREADED BRASS INSERT

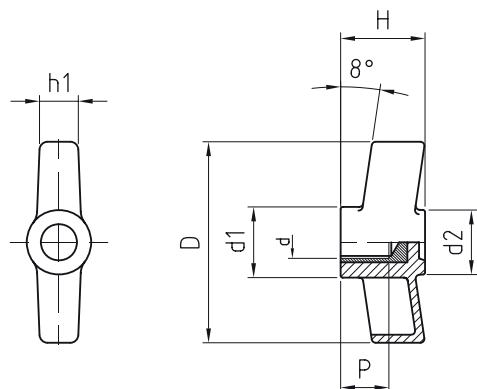
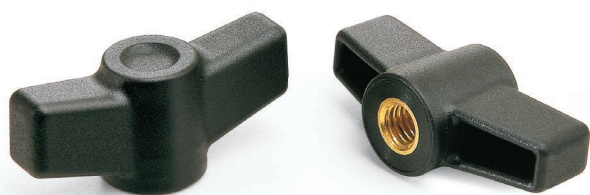

» **Tecnopolimero** rinforzato con fibra di vetro, colore standard nero, resistente a solventi, oli e grassi.

» **Boccola** in ottone con foro cieco filettato.

» Technopolymer, fiberglass-reinforced, black colour, solvent-oils-greaseproof.

» Brass insert, threaded blind hole.

Cod. Code	D	d	d1	d2	H	h1	P	Gr.
11970000	30	M04	14	12	16	6	8	6
11970050	30	M05	14	12	16	6	10	6,5
11970100	30	M06	14	12	16	6	12	7
11970150	30	M08	14	12	16	6	11	7,5
11970400	50	M05	18	16	22	10	10	12,5
11970450	50	M06	18	16	22	10	12	13
11970500	50	M08	18	16	22	10	11	13,5
11970550	50	M10	18	16	22	10	16	15

GALLETTO CON BOCCOLA
OTTONE PASSANTE
WING NUT, WITH THREADED BRASS THRU-INSERT

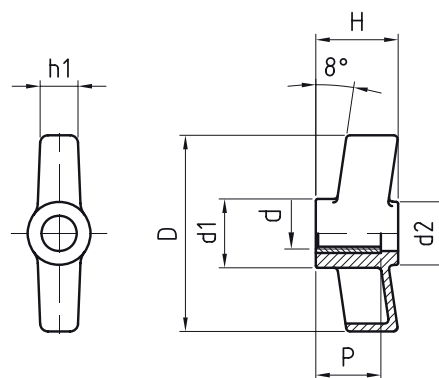
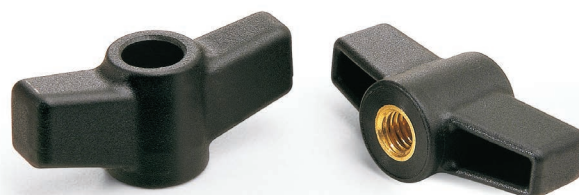

» **Tecnopolimero** rinforzato con fibra di vetro, colore standard nero, resistente a solventi, oli e grassi.

» **Boccola** in ottone con foro passante filettato.

» Disponibile anche con inserto in ACCIAIO ZINCATO ed altri colori a richiesta (vedi pag. 6).

» Technopolymer, fiberglass-reinforced, black colour, solvents-oils-greaseproof.

» Brass insert, threaded thru-hole.

» ZINC-PLATED insert and colours on request (see page 5).

Cod. Code	D	d	d1	d2	H	h1	P	Gr.
11980000	30	M04	14	12	16	6	8	6
11980050	30	M05	14	12	16	6	10	6,5
11980100	30	M06	14	12	16	6	12	7
11980150	30	M08	14	12	16	6	11	7,5
11980400	50	M05	18	16	22	10	10	12,5
11980450	50	M06	18	16	22	10	12	13
11980500	50	M08	18	16	22	10	11	13,5
11980550	50	M10	18	16	22	10	16	15