

VOLANTINO A FASCIA CON MANIGLIA A SCATTO RIBALTABILE

BAR-PATTERN HANDWHEEL WITH SNAP HANDLE, COLLAPSIBLE

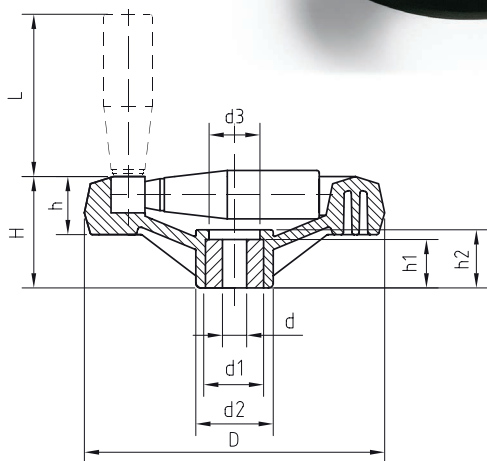

- » **Tecnopolimero** di colore nero rinforzato con fibra di vetro, resistente a solventi, oli, grassi ed altri agenti chimici.
- » **Mozzo** in AVP zincato con fori standard.
- » **Mostrina** centrale autoadesiva in alluminio anodizzato opaco da applicare dopo il montaggio.
- » **Maniglia** a scatto ribaltabile (vedi pag. 52)
- » Versioni speciali e colori a richiesta (vedi pag. 4/5).

- » Technopolymer, fiberglass-reinforced, black colour, solvents- oils-greases and other chemical agents-proof.
- » Zinc-plated steel hub, with standard holes.
- » Anodized aluminium selfadhesive central cover, to be applied after mounting.
- » Snap handle, collapsible (see page 52)
- » Special items and colours on request (see page 4/5).

Cod. Code	D	d	d1	d2	d3	H	h	h1	h2	L	Gr.
03020000	80	8	18	24	15	35	18	17	23	46	101
03020025	80	10	18	24	15	35	18	17	23	46	101
03020050	100	10	18	24	15	37	20	17	23	46	123
03020100	100	12	18	24	15	37	20	17	23	46	115
03020150	126	10	24	32	21	46	24	21	25	65	308
03020200	126	12	24	32	21	46	24	21	25	65	294
03020250	126	14	24	32	21	46	24	21	25	65	288
03020255	126	15	24	32	21	46	24	21	25	65	288
03020300	160	10	26	40	25	52	26,5	25	31	65	400
03020340	160	12	26	40	25	52	26,5	25	31	65	394
03020350	160	14	26	40	25	52	26,5	25	31	65	388
03020400	160	16	26	40	25	52	26,5	25	31	65	378
03020450	200	10	30	50	28	62	28	28	34	75	709
03020500	200	16	30	50	28	62	28	28	34	75	677
03020550	200	20	30	50	28	62	28	28	34	75	651

VOLANTINO A FASCIA CON IMPUGNATURA GIREVOLE

BAR-PATTERN HANDWHEEL WITH REVOLVING HANDLE

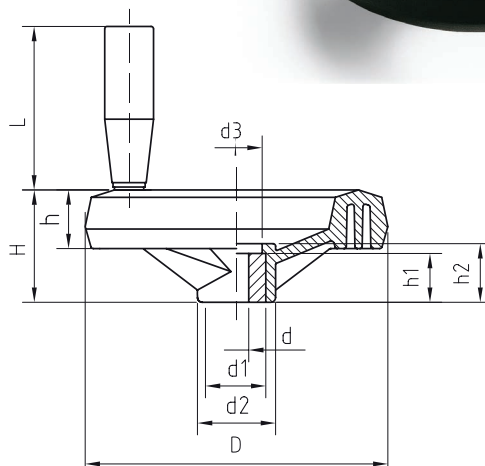

- » **Tecnopolimero** di colore nero rinforzato con fibra di vetro, resistente a solventi, oli, grassi ed altri agenti chimici.
- » **Mozzo** in AVP zincato con fori standard.
- » **Mostrina** centrale autoadesiva in alluminio anodizzato opaco da applicare dopo il montaggio.
- » **Impugnatura** girevole (vedi pag. 53).
- » Versioni speciali e colori a richiesta (vedi pag. 4/5).

- » Technopolymer, fiberglass-reinforced, black colour, solvents-oils-greases and other chemical agents-proof.
- » Zinc-plated steel hub, with standard holes.
- » Anodized aluminium selfadhesive central cover, to be applied after mounting.
- » Revolving handle (see page 53).
- » Special items and colours on request (see page 4/5).

Cod. Code	D	d	d1	d2	d3	H	h	h1	h2	L	Gr.
03800000	80	8	18	24	15	35	18	17	23	50	92
03800025	80	10	18	24	15	35	18	17	23	50	92
03800050	100	10	18	24	15	37	20	17	23	50	108
03800100	100	12	18	24	15	37	20	17	23	50	113
03800150	126	10	24	32	21	46	24	21	25	70	296
03800200	126	12	24	32	21	46	24	21	25	70	290
03800250	126	14	24	32	21	46	24	21	25	70	284
03800255	126	15	24	32	21	46	24	21	25	70	284
03800300	160	10	26	40	25	52	26,5	25	31	85	443
03800340	160	12	26	40	25	52	26,5	25	31	85	435
03800350	160	14	26	40	25	52	26,5	25	31	85	427
03800400	160	16	26	40	25	52	26,5	25	31	85	419
03800450	200	10	30	50	28	62	28	28	34	85	723
03800500	200	16	30	50	28	62	28	28	34	85	689
03800550	200	20	30	50	28	62	28	28	34	85	665